

LGES-5048 LGES-5048-NS Hybrid Inverter

User Manual



TABLE OF CONTENTS

01 Introduction	1
1.1 Operation Modes Introduction.....	1
1.2 Safety and Warning.....	2
1.3 Product Overview	4
02 Installation Instructions	6
2.1 Unacceptable Installations.....	6
2.2 Packing List	6
2.3 Mounting	7
2.3.1 Select Mounting Location.....	7
2.3.2 Mounting	8
2.4 Electrical Wiring Connection	9
2.4.1 PE Cable Connection	9
2.4.2 PV Wiring Connection	10
2.4.3 Battery Wiring Connection	11
2.4.4 On-Grid&Back-up Connection.....	12
2.4.5 Smart Meter & CT Connections	15
2.5 DRED & Remote Shutdown Device Connection.....	17
2.6 WiFi & WiFi/LAN Module Connection	18
2.7 Earth Fault Alarm Connection.....	18
03 MANUAL OPERATION	21
3.1 Wi-Fi Configuration	21
3.2 Startup/Shutdown Procedure	22
3.3 LGES PV Master App.....	23
3.4 LG RESU Home Monitor App.....	23

04 OTHER..... 24

- 4.1 Error Messages.....24
- 4.2 Troubleshooting26
- 4.3 Disclaimer28
- 4.4 Technical Parameters30

01 Introduction

LGES-5048 is a hybrid or bidirectional solar inverter, applicable to solar systems connected to the utility grid and LG Energy Solution RESU 48V batteries. The Inverter should not be installed in multiple phase combinations

The energy produced by the PV system is used to power household loads, charge the battery, and export excess energy to the utility grid. When household loads exceed PV production, the battery is discharged to support the loads and minimize utility grid import.

With the optional addition of remote control, such as Virtual Power Plant (VPP) participation, the inverter and battery combination can further optimise energy usage according to price signals.

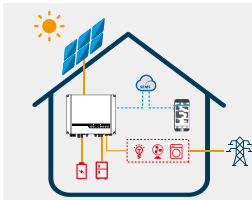

The introduction describes a general working situation of the LGES system. The operation mode can be adjusted on LGES PV Master App up to the system layout. The general operation modes are as below:

1.1 Operation Modes Introduction

LGES-5048 system normally has the following operation modes based on your configuration and layout conditions.

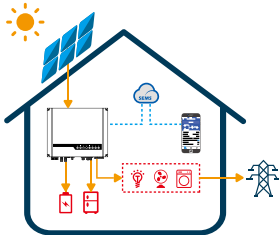

Mode I

The energy produced by the PV system is used to optimize self-consumption needs. The excess energy is used to recharge the batteries, any remaining excess is then exported to the grid.

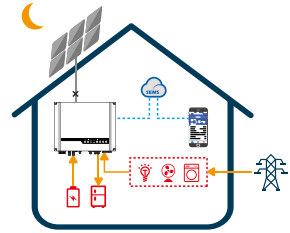

Mode II

When there is no PV, and the battery is sufficient, it can supply the load together with grid power.

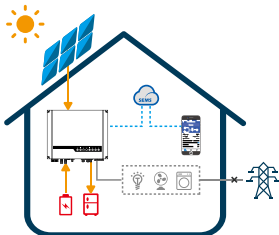

Mode III

When grid fails, the system will automatically switches to back-up mode. The back-up loads can be supplied by both PV and battery energy.

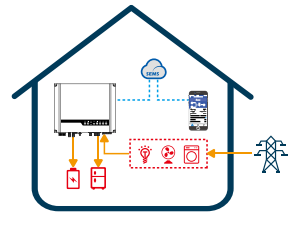

Mode IV

Battery could be charged by grid, and charge time/power could be set on LGES PV Master or remotely controlled.

1.2 Safety and Warning

LGES-5048 from LG Energy Solution Ltd strictly complies with related safety rules for product design and testing. Please read and follow all the instructions and cautions on the inverter or user manual during installation, operation or maintenance. Improper operation might cause personal or property damage.

Symbol Explanation



Caution!
Failure to observe any warnings contained in this manual may result in injury.



Danger - high voltage and electric shock!



Danger - hot surface!



The components of the product can be recycled.



This side up! This package must always be transported, handled and stored in such a way that the arrows always point upwards.



No more than six (6) identical packages being stacked on each other.



Products shall not be disposed as household waste.



Fragile - The package/product should be handled carefully and never be tipped over or slung.



Refer to the operating instructions.



Keep dry! The package/product must be protected from excessive humidity and must be stored under cover.



This symbol indicates that you should wait at least 5mins after disconnecting the inverter from the utility grid and from the PV panel before touching any inner live parts.



CE mark.

Safety Warnings

Installation and operation of the inverter must be performed by qualified electricians, in compliance with all local standards, wiring rules and requirements of local grid authorities, e.g. AS 4777 and AS/NZS 3000 in Australia.

Before any wiring connection or electrical operation on inverter, all battery and AC power must be disconnected from inverter for at least 5 minutes to make sure inverter is totally isolated to avoid electric shock.

The temperature of inverter surface might exceed 60°C during operation, so please make sure it has cooled down before touching it, and make sure the inverter is out of reach of children.

Do not open the inverter's cover or change any components without manufacturer's authorization, otherwise the warranty commitment for the inverter will be invalid.

Usage and operation of the inverter must follow instructions in this user manual, otherwise the protection design might be impaired and warranty commitment for the inverter will be invalid.

Appropriate methods must be adopted to protect inverter from static damage. Any damage caused by static is not warranted by manufacturer.

PV negative (PV-) and battery negative (BAT-) on inverter side is not grounded as default design. Connecting PV- to EARTH is strictly forbidden.

PV modules used on the inverter must have an IEC61730 class A rating, and the total open-circuit voltage of PV string/array is lower than the maximum rated DC input voltage of the inverter. Any damage caused by PV over-voltage is beyond warranty.

The inverter, with built-in RCMU, will exclude possibility of DC residual current to 6mA, thus in the system an external RCD (type A) can be used(≥ 30 mA).

In Australia, the inverter internal switching does not maintain neutral integrity, which must be addressed by external connection arrangements like in the system connection diagram for Australia on page 17

In Australia, output of back-up side in switchbox should be labeled on "Main Switch UPS Supply". The output of normal load side in switch box should be labeled "Main Switch Inverter Supply".



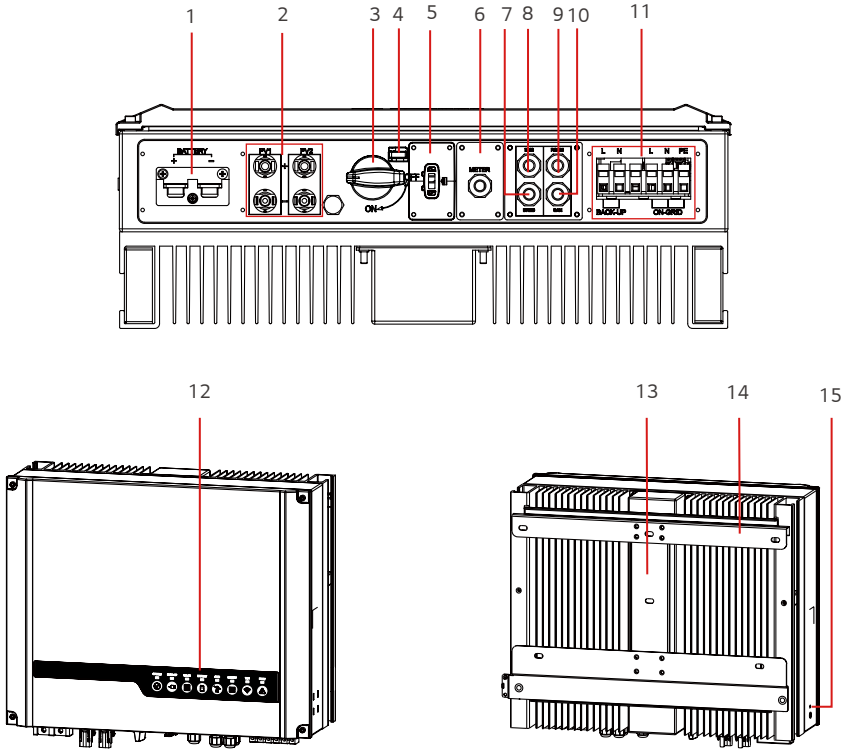

























1.3 Product Overview



- | | | |
|---|--|-----------------------------|
| 1. Battery Terminal (BATTERY +/-) | 2. PV Input Terminal (PV1/ PV2) | 3. DC Switch (optional) |
| 4. DC Switch Locking Hole | 5. Communication Module Port (WiFi or LAN) | 6. METER Communication Port |
| 7. DRED or Remote Shutdown Communication Port | 8. BMS Communication Port | 9. RS485 Communication Port |
| 10. Reserved Port | 11. AC Terminal (ON-GRID and BACKUP) | 12. Indicators |
| 13. Mounting Plate | 14. Heat Sink | 15. PE Terminal |

If the inverter is not equipped with a DC switch (LGES-5048-NS), an external DC breaker shall be added. The external DC breaker shall be AU/NZ certified; Complied to AS60947.3:2018; Be classified as DC-PV 2; With ratings and properties suitable for the intended application conditions such as outdoor, exposed to sunshine, on non-combustible material surface.

LED Indicators

Indicator	Status	Explanation
SYSTEM		ON = System is ready.
		BLINK = System is starting.
		OFF = System is not operating.
BACK-UP		ON = Back-up is ready / power available.
		OFF = Back-up is off / no power available.
SOLAR		ON = Solar inputs #1 and #2 are active.
		BLINK 1 = Solar input #1 is active /#2 is not active.
		BLINK 2 = Solar input #2 is active /#1 is not active.
		OFF = Solar input #1 and #2 are not active.
BATTERY		ON = Battery is charging.
		BLINK 1 = Battery is discharging.
		BLINK 2 = Battery is low / soc is low.
		OFF = Battery is disconnected/not active.
GRID		ON = Grid is active and connected.
		BLINK = Grid is active but not connected.
		OFF = Grid is not active.
ENERGY		ON = Consuming energy from grid / buying.
		BLINK 1 = Supplying energy to grid / zeroing.
		BLINK 2 = Supplying energy to grid / selling.
		OFF = Grid is not connected or system is not operating.
WiFi		ON = WiFi connected / active.
		BLINK 1 = WiFi system resetting.
		BLINK 2 = WiFi not connect to router.
		BLINK 4 = WiFi server problem.
		OFF = WiFi not active.
FAULT		ON = Fault has occurred.
		BLINK = Overload of back-up output / reduce load.
		OFF = No fault.

02 Installation Instructions





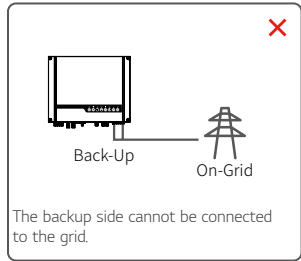
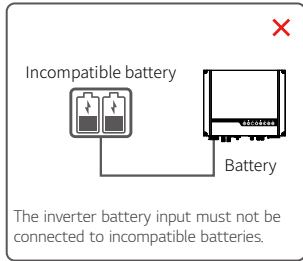
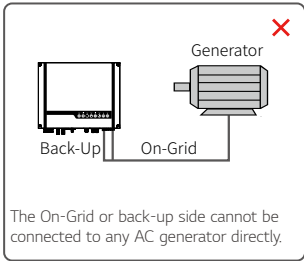
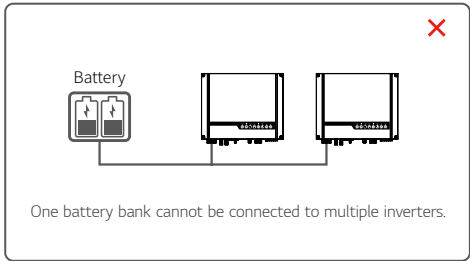
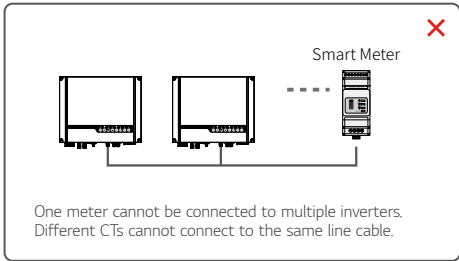
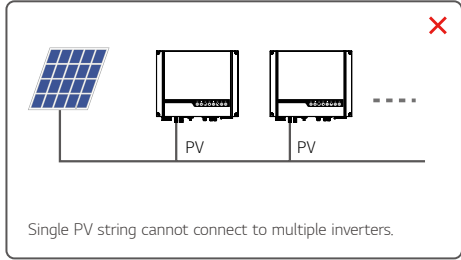
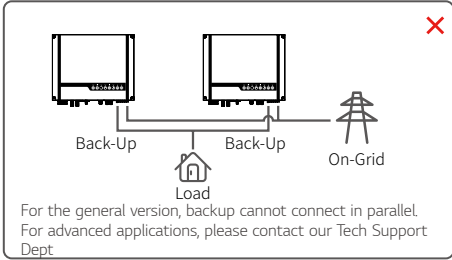





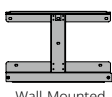



2.1 Unacceptable Installations

Please avoid the following installations which will damage the system or the Inverter. The following installations should be avoided. Any damage caused will not be covered by the warranty policy.



2.2 Packing List

Upon receiving the hybrid inverter, please check if any of the components as shown below are missing or broken.

- | | | | | | | | | |
|--|---|--|---|---|--|--|---|--|
| 
Inverter | 
Wall-Mounted Bracket | 
Smart Meter With CT | 
Positive PV Plug | 
Negative PV Plug | 
Battery Cover | 
Clip | | |
| 
Battery Terminal | 
Pin Terminal | 
Hexagon screw | 
Fixed Screw | 
PE Terminal | 
Expansion Bolts | 
WiFi Module | 
Bluetooth Module | 
Documentations |

2.3 Mounting

2.3.1 Select Mounting Location

For inverter's protection and convenient maintenance, mounting location for inverter should be selected carefully based on the following rules:

Rule 1. Any part of this system shouldn't block the switch and breaker from disconnecting the inverter from DC and AC power.

Rule 2. Inverter should be installed on a solid surface, where it is suitable for inverter's dimensions and weight.

Rule 3. Inverter should be installed vertically or lie on a slope by a max of 15°

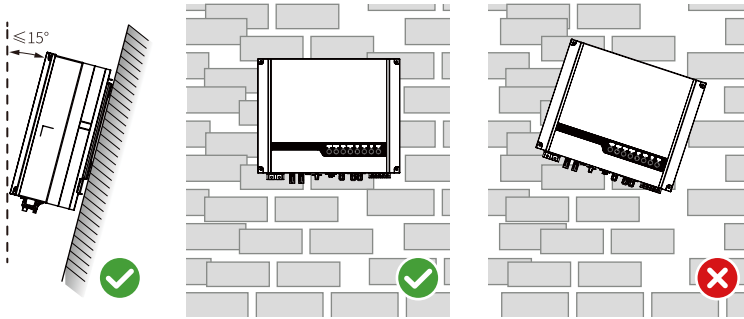

Rule 4. Ambient temperature should be lower than 45°C. The temperature and humidity at the installation site should be within the appropriate range (60 °C for outdoor unconditioned with solar effects).

Rule 5. It is recommended that the installation of the inverter should be prevented from direct sunlight, snow, rain and other negative influences which may cause function impact or life aging.

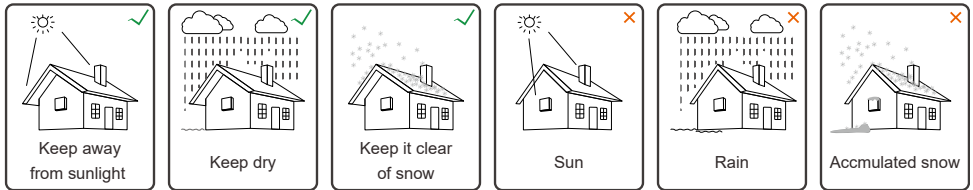

Rule 6. Inverter should be installed at eye level for convenient maintenance.

Rule 7. Product label on inverter should be clearly visible after installation.

Rule 8. Do not install the inverter when it is snowing or raining. If you have to, pay attention to the waterproof and moisture-proof of the inverter and distribution box.

Rule 9. Leave enough space around the inverter according to the below figure for natural heat dissipation.

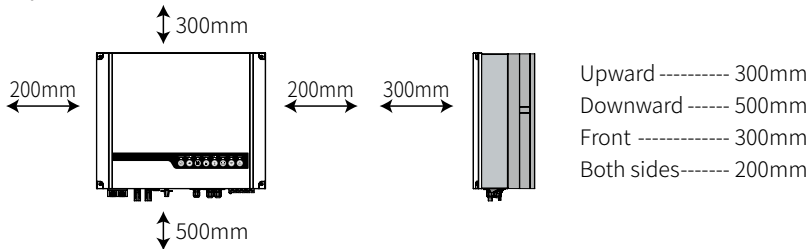

If there is any radio or wireless communication equipment below 30mhz near the inverter, make sure that:



1. Install the inverter at least 30m far away from the high-precision wireless equipment.
2. Add ferrite core with multi coil winding or low pass EMI filter to the DC cable or AC cable.

2.3.2 Mounting



Remember that this inverter is heavy! Please be careful when lifting out from the package.

The inverter is suitable for mounting on concrete or other non-combustible surfaces only.

1

Please use the mounting bracket as a template to drill 4 holes in the correct positions (10mm in diameter and 80mm in depth).

Use the expansion bolts in the accessory box and tightly attach the mounting bracket to the wall.

Note: Bearing capacity of the wall must be higher than 30kg, otherwise it may not be able to keep the inverter from dropping.

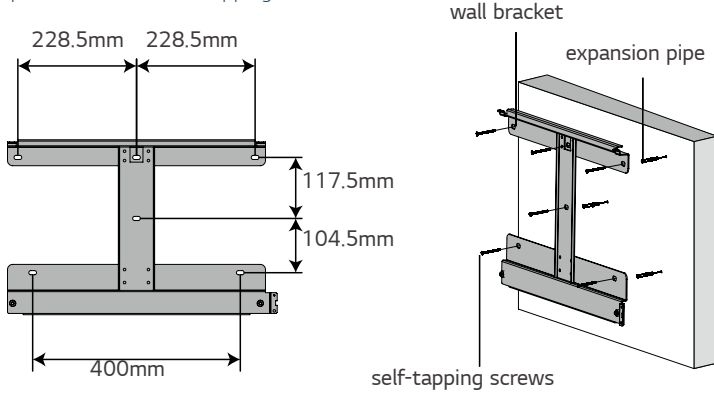

2

FOR AUSTRALIA ONLY. Lock the DC switch before mounting. Make sure that the DC switch is locked unless the inverter is powered on.

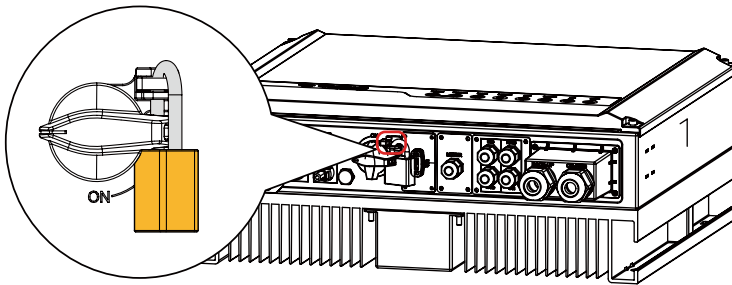

3

Carry the inverter by holding the heat sink on two sides and place the inverter on the mounting bracket.

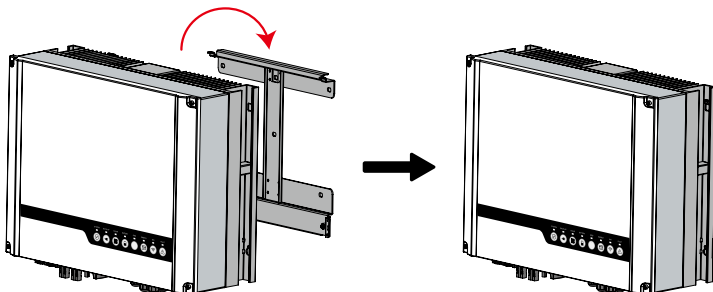

- 4 The inverters can be locked for anti-theft purposes if this is necessary for individual requirements.

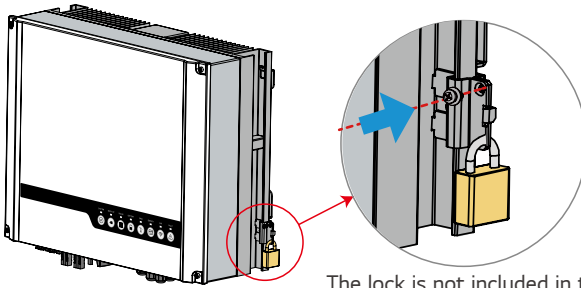

The lock is not included in the package and can be purchased by the user.

2.4 Electrical Wiring Connection

2.4.1 PE Cable Connection

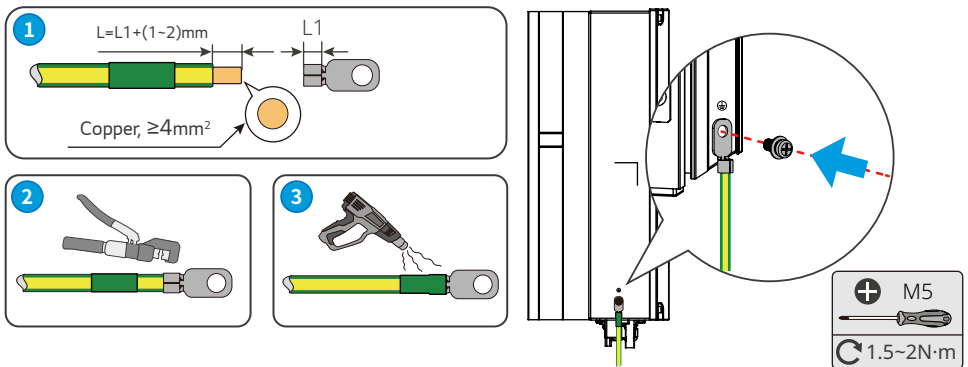

- Disconnect the PE cable after dismantling the equipment if needed.
- To improve the corrosion resistance of the terminal, it is recommended to apply silica gel or paint on the ground terminal after installing the PE cable.
- The PE cable should be prepared by customers. Recommended specifications:
 - Type: single-core outdoor copper cable.
 - Conductor cross-sectional area $S \geq 4 \text{mm}^2$.

2.4.2 PV Wiring Connection

Before connecting PV panels/strings to inverter, please make sure requirements are followed as below:

- The total short-circuit current of a PV string must not exceed the inverter's max DC current.
- The minimum impedance to earth of the PV module shall be greater than R . $R = \text{Max.Input Voltage (V)} / 30\text{mA}$, i.e. $R = 1100\text{V} / 30\text{mA} = 36.7\text{k}\Omega$ or $R = 1000\text{V} / 30\text{mA} = 33.4\text{k}\Omega$.
- The PV string must not be connected to the earth/grounding conductor.
- Use the right PV plugs in the accessory box. (BAT plugs are similar to PV plugs. Please check before using them.)

Note: There are MC4 plugs in the accessory box. The connection details are shown below.

1 Prepare the PV cables and PV plugs.

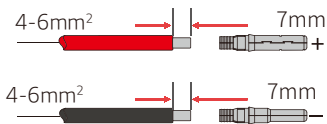

Note:

1. Please use the PV plugs and connectors from the accessory box.
2. The PV cable should be a standard 4-6mm².

2 Connect the PV cable to the PV connectors.

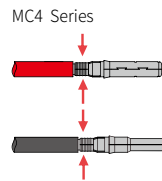

Note:

1. Crimp the PV cable tightly onto the connectors.
2. There will be a clicking sound if the connectors are inserted correctly into the PV plugs.

3 Screw the cap on and plug it into the inverter side.

Note: There will be a clicking sound if the connectors are inserted correctly into the PV plugs.

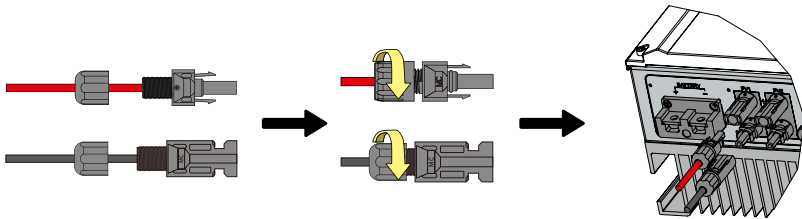

The polarity of the PV strings must not be connected in a reverse manner. Otherwise, the inverter could be damaged.

2.4.3 Battery Wiring Connection

Please be careful of any electric shock or chemical hazards.

Make sure there is an **external DC breaker (125A)** connected to the battery circuit.



Make sure that the breaker is off and battery is LG Energy Solution RESU 6.5/10/12/13 48V nominal battery only before connecting battery to inverter. Make sure inverter is totally isolated from PV and AC power.

For lithium battery (pack) the capacity should be 50Ah or larger. Battery cable requirements are as following.

You are recommended to refer to the battery user manual as well when selecting the battery cable.

Grade	Description	Value
A	Outside diameter Insulation	10-14mm
B	Insulation section	NA
C	Conductor core section	35mm ²



Battery wiring connection process

- 1 Prepare battery cables and accessories and put battery power cable through battery cover.

Note:

1. Please use accessories from accessory box.
2. Battery power cable should be 35mm².

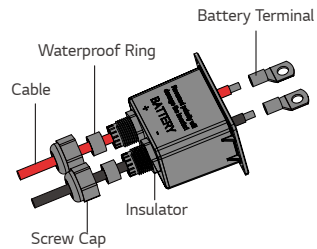

- 2 Make battery terminals
 - Strip cable coat, revealing 10mm length of metal core.
 - Use special crimper to compress battery terminal tightly.

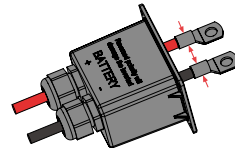

- 3 Connect battery terminal onto inverter.

Note:

Please make sure polarity (+/-) of battery are not reversed.

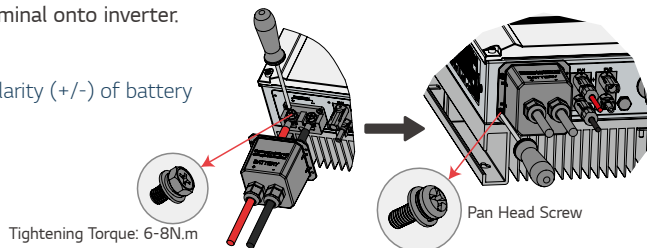

* For the compatible LG RESU batteries, please refer to battery connection in LGES QUICK INSTALLATION INSTRUCTIONS.

Battery Protection

Battery will provide charge/discharge current limitation under the following conditions:

- Battery SOC is lower than I-DOD (Depth of discharge).
- Battery voltage is lower than discharge voltage.
- Battery over temperature protection
- Battery communication is abnormal for lithium battery.
- BMS charge/discharge limitation for lithium.

When charge/discharge current limitation protection happens:

- Under on-grid mode, battery charge/discharge operation could be abnormal.
- Under off-grid mode, Back-Up supply will shut down.

Note:

- The inverter and battery cannot be used in off-grid designs
- Under on-grid mode, battery is protected from over discharge by DOD and discharge voltage.
- The DOD setting of a battery prevents the inverter from discharging battery reserve power. As soon as the DOD is reached the load of building will only be supported by either PV power or the grid. If there are continuous days when little or no battery charging occurs, the battery may continue to self-consume energy to support communications with the inverter.

2.4.4 On-Grid & Back-up Connection

An external AC breaker is needed for on-grid connection to isolate the inverter from the utility grid when necessary.

The requirements for the on-grid AC breaker are shown below.

Inverter Model	AC Breaker Specification
LGES-5048	40A / 230V (e.g. DZ47-60 C40)
LGES-5048-NS	40A / 230V (e.g. DZ47-60 C40)

Note: The absence of AC breaker will lead to inverter damage if an electrical short circuit happens on grid side.

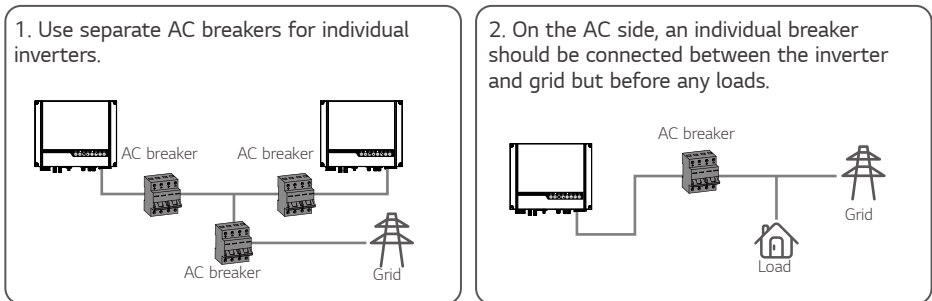

Requirement of AC cable connected to On-Grid and Back-Up side.



Make sure the inverter is totally isolated from any DC or AC power before connecting the AC cable.

Note:

1. Neutral cable shall be blue, line cable shall be black or brown (preferred) and protective earth cable shall be yellow-green.
2. For AC cables, PE cable shall be longer than N&L cables, so in case that the AC cable slips or is taken out, the protecting earth conductor will be the last to take the strain.

- 1 Prepare the terminals and AC cables according to the right table.

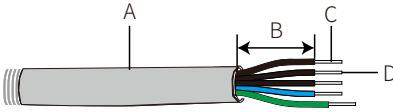

Grade	Description	Value
A	Outside diameter	13-18 mm
B	Separated wire length	20-25 mm
C	Conductor wire length	7-9 mm
D	Conductor core section	4-6 mm ²

- 2 Put AC cable through terminal cover as shown in the figure.

Note: Please use the terminals in accessory box.

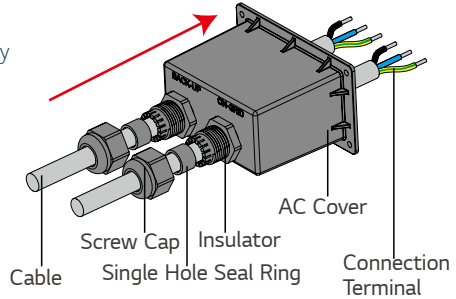

- 3 Press the 6 connectors on cable conductor core tightly.

Note: Make sure cable jacket is not locked within the connector.

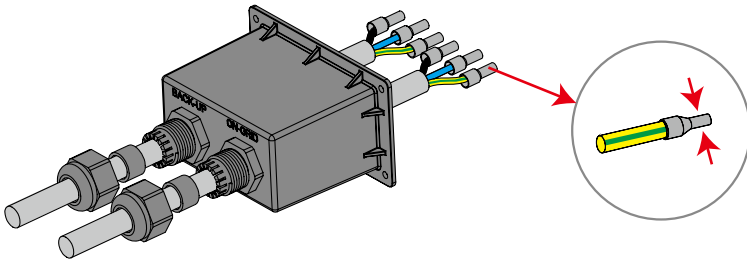

- 4

Tightening torque
2.0-2.5N·m

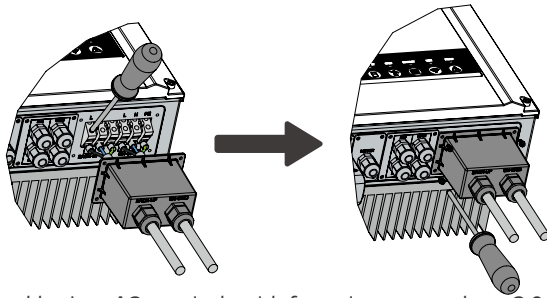

1. Connect the assembled AC cables into AC terminals with fastening torque about 2.0-2.5N·m.
Note: Connect back-up terminals before connecting on-grid terminals. Make sure it is not connected to the wrong side.
2. Lock the cover and screw the cap.

Special adjustable settings

The inverter has a field where the user can set functions, such as trip points, trip time, time of reconnection, active and invalid of QU curve and PU curve etc. by special firmware. Please contact Technical Support for the special firmware and adjustable methods

Declarations For The Backup Function

The back-up output of LGES hybrid inverters have limited overload ability.

For details please refer to the technical parameters (Page 30).

The inverter has self-protection de-rating at high ambient temperature.

The following statement lays out general policies governing LGES-5048 (&NS).

1. Standard PV installation typically consists of the connection of the inverter with both panels and batteries. In the case where the system is not connected to the batteries, the back-up function is strongly not advised for use. Manufacturer shall not cover the standard warranty and be liable for any consequences arising from users not following this instruction.
2. Under normal circumstances, the back-up switching time is less than 10 ms (the minimal condition to be considered as the UPS level). However, some external factors may cause the system failing on back-up mode. As such, we recommend the users to be aware of conditions and follow the instructions as below:
 - Do not connect loads when they are dependent on a stable energy supply for a reliable operation.
 - Do not connect the loads which may in total exceed the maximum back-up capacity. Even when grid is present, this will cause overload.
 - Try to avoid those loads which may create very high start-up current surges such as inverter air-conditioner, high-power pump etc.
 - Due to the condition of the battery itself, battery current might be limited by some factors including but not limited to the temperature, weather etc.

Acceptable Loads Are As Below:

LGES-5048 series inverter is able to supply a continuous 4600VA output or maintain a 6900VA output less than 10 seconds on back-up side to support loads. The inverter also has self-protection against de-rating at high ambient temperature.

- Inductive Load: Maximum 1.5KVA for single inductive load, maximum 2.5KVA for total inductive load power.
- Capacitive Load: Total capacitive load (like computer, switch power etc.)power \leq 3.0KVA. (Any load with high inrush current at start-up is not accepted)

Note:

For convenient maintenance, please install a SP3T switch on back-up and on-grid side. Then it is adjustable to support load by back-up or by grid or default settings.

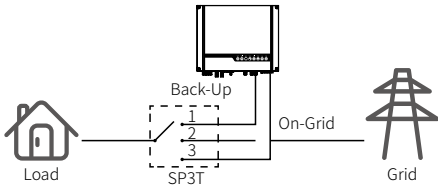

1. Back-up load is supplied from back-up side.
2. Back-up load is isolated.
3. Back-up load is supplied from grid side.

Declarations For Backup Overload Protection

Inverter will restart itself if overload protection triggers. The preparation time for restarting will be longer and longer (one hour at most) if overload protection repeats. Take following steps to restart inverter immediately.

Decrease back-up load power within maximum limitation.

On LGES PV Master App > Advanced Settings > Click "Reset Backup Overload History".

2.4.5 Smart Meter & CT Connections

 Make sure the AC cable is totally isolated from AC power before connecting the Smart Meter and CT.

A Smart Meter with the CT in product box is compulsory for LGES system installation. It can be used to detect the grid voltages and current directions, provide the operating condition of the LGES inverter via RS485 communications.

Note:

1. The Smart Meter with CT is already configured ; please do not change any settings on the Smart Meter.
2. One Smart Meter can be used with only one LGES series inverter.
3. If LGES series inverter is used in a three-phase grid with a three-phase smart meter, the three CTs must be used for one Smart Meter, and must be connected on the same phase with Smart Meter power cable.

Smart Meter & CT connection diagram

• For Single Phase Grid

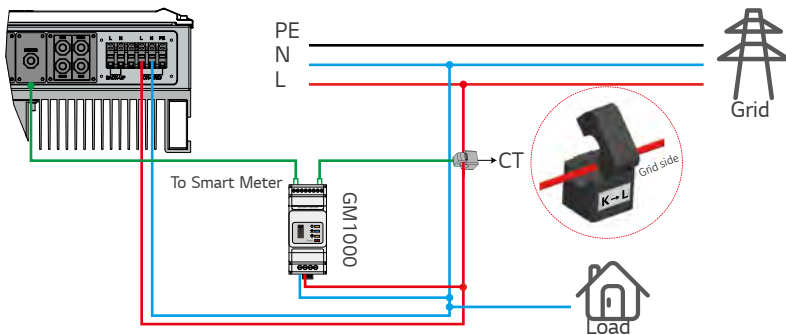

• For Three Phase Grid

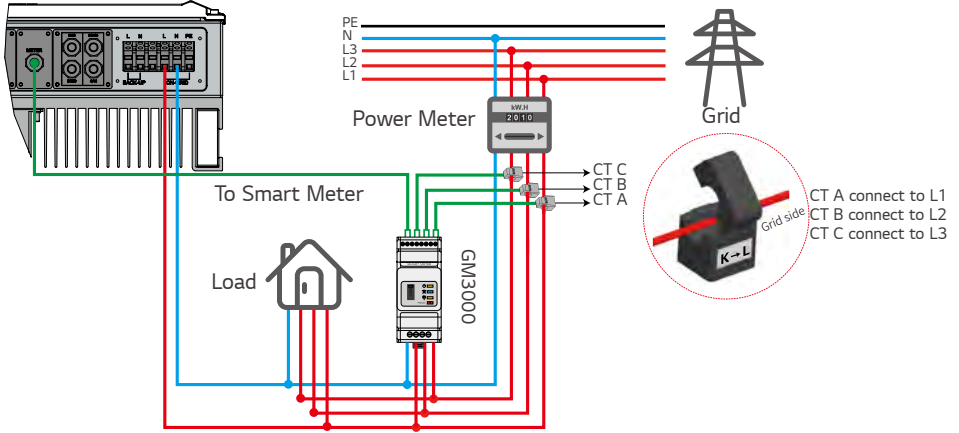

Note:

1. CT cable is 3m as default, please do not extend.
2. Smart Meter communication cable (RJ45) is attached on the inverter ("To Smart Meter" cable), could be extended to max 100m, and must use standard RJ45 cable and plug, as below:
3. Single-phase Smart Meter GM1000 is supplied with inverter. For 3-phase grid, use optional GM3000 (available from distributor).

Detailed PIN Functions Of Each Port On The Inverter

BMS: CAN communication is configured by default. If 485 communication is used, please contact the Technical Support to replace this with the correct communication cable.

Position	Color	BMS Function	Smart Meter Function	EMS
1	Orange & white	485_A2	NC	485_A
2	Orange	NC	NC	485_B
3	Green & white	485_B2	485_B1	485_A
4	Blue	CAN_H	NC	NC
5	Blue & white	CAN_L	NC	NC
6	Green	NC	485_A1	485_B
7	Brown & white	NC	485_B1	NC
8	Brown	NC	485_A1	NC

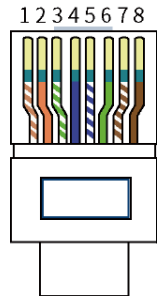

Smart Meter LED Indications

STATUS	OFF	ON	Blinking
POWER	Not working	Working	/
ENERGY	/	Importing	Exporting
COM	Single blink when data is transferred to the inverter		

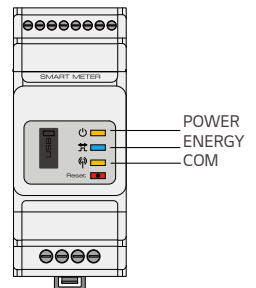

2.5 DRED & Remote Shutdown Device Connection

DRED (Demand response enabling device) is used for Australia safety requirements. Inverter integrates control logic and provides an interface for DRED. The DRED is not provided by inverter manufacturer.

Detailed connection of DRED & Remote Shutdown are shown below.

- 1 Screw this plate off from the inverter.
Note: DRED should be connected through "DRED Port" as the figure shows.

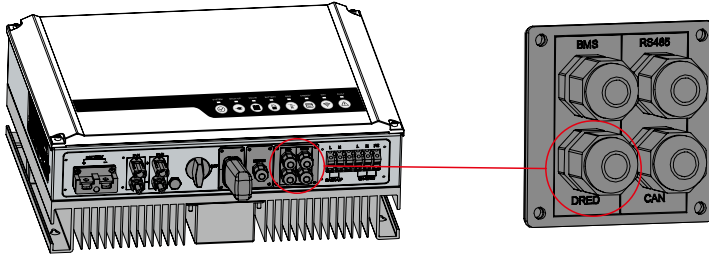

- 2
 1. Plug out the 6-pin terminal and dismantle the resistor on it.
 2. Plug the resistor out, leave the 6-pin terminal for next step.

Note: The 6-pin terminal in the inverter has the same function as DRED. Please leave it in the inverter if no external device is connected.

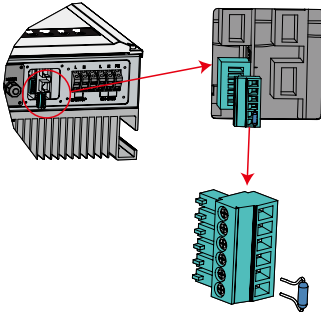

3-1 For DRED

1. Put DRED cable through the plate.
2. Connect DRED cable on the 6-pin terminal.

The function of each connection position as below.

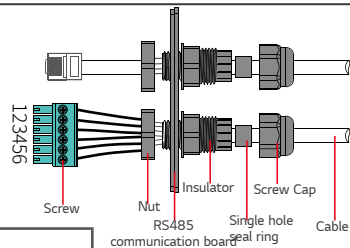

NO	1	2	3	4	5	6
Function	DRM1/5	DRM2/6	DRM3/7	DRM4/8	REFGEN	COM /DRMO

3-2 For Remote Shutdown

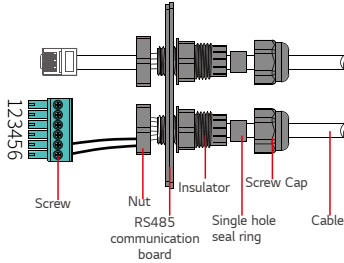

1. Put the cable through the plate.
2. Wiring from the No. 5 and 6 holes respectively

NO	5	6
Function	REFGEN	COM /DRMO

4 Connect DRED terminal to the right position onto the inverter.

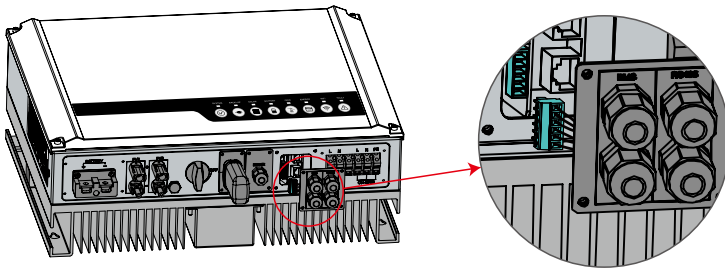

2.6 WiFi & WiFi/LAN Module Connection

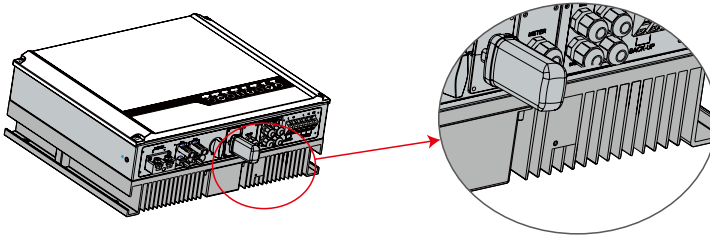

2.7 Earth Fault Alarm Connection

The inverter complies with IEC 62109-2 13.9. Fault indicator LED on inverter cover will light up and the system will email the fault information to customer. It must be installed in a high traffic area where the LED would be noticed.

Inverter should be installed at eye level for convenient maintenance.

Wiring System For The Hybrid Inverter

Note: This diagram indicates the wiring structure of the hybrid inverter, not the electric wiring standard.

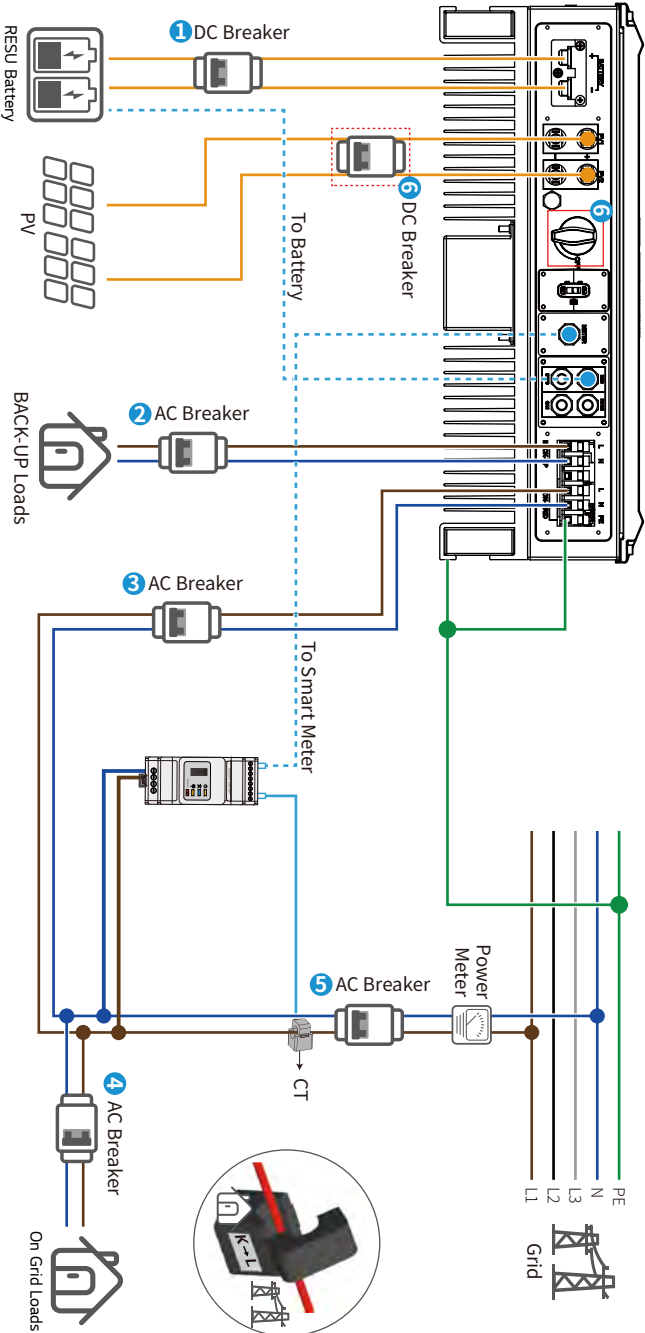

Inverter	①	②	③	④⑤	⑥※
LGES-5048	125A/60V DC Breaker	40A/230V AC breaker	40A/230V AC breaker	Depends on household loads	30A/600V DC Breaker
LGES-5048-NS					

Please select the breaker according to the specifications below:

1. Only for RESU 48V battery which has BMS communication.
 2. Direction of the CT cannot be connected in reverse, please follow "House→Grid" direction to do the connection.
- ※ If the inverter is not equipped with a DC switch (LGES-5048-NS), an external DC breaker shall be added.

System Connection Diagrams

Note: According to Australian safety requirements, the neutral cables of the on-grid side and backup-side must be connected at the neutral bar of the distribution box. Otherwise, the backup function will not work.

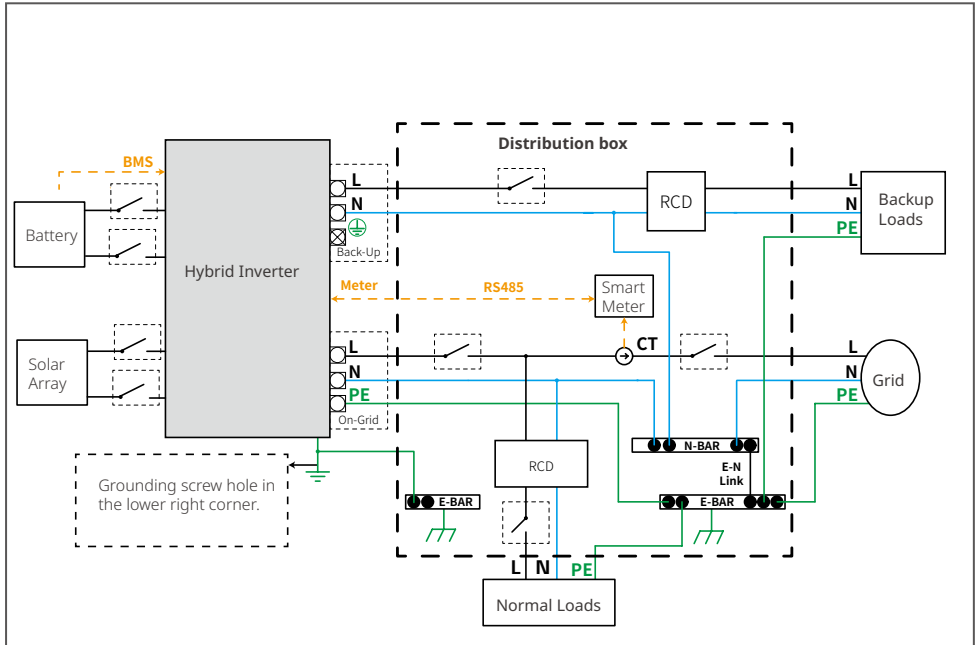

Wiring with SP3T Bypass Switch

Notice: The purpose of SP3T bypass switch is to allow for continued operation of back-up loads in case of inverter fault. SP3T bypass switch is not provided with inverter, it can be purchased from electrical wholesalers.

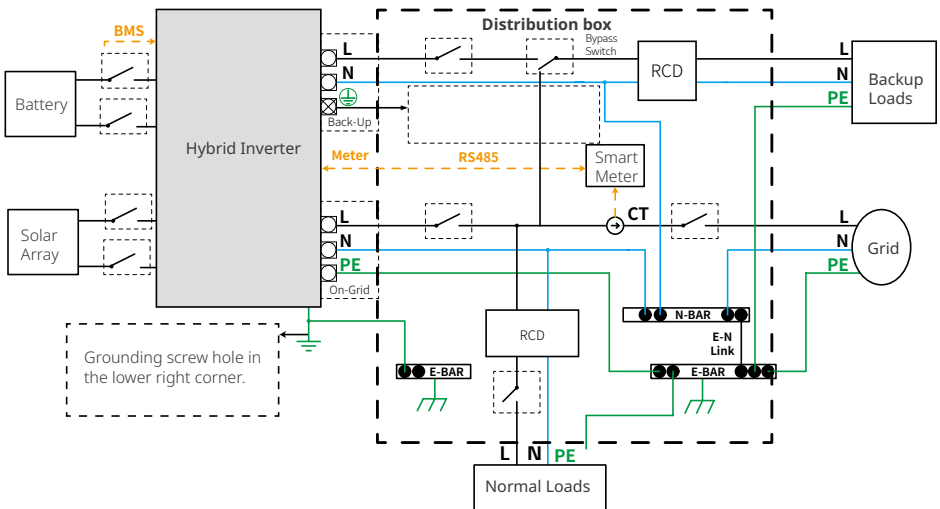

03 MANUAL OPERATION

3.1 Wi-Fi Configuration

This part shows configuration on web page. You can also complete the configuration with LGES PV Master App. Wi-Fi configuration is absolutely necessary for online monitoring and maintenance.

Preparation:

1. The inverter must be powered up with battery or grid power.
2. A router with internet access to the website www.lgresuhomemonitor.com is required.

1

1. Connect Solar-Wi-Fi* to your PC or smart phone (* its name is the last 8 characters of the inverter's serial number); Password:12345678.
2. Open your browser and logon to 10.10.100.253 Admin (User): admin;
3. Password: admin.
4. Then click "OK".

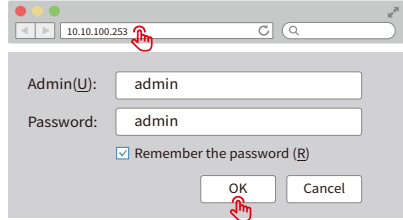

2

1. Click "Start Setup" to choose your router.
2. Then click "Next".

Device information

Firmware version	1.6.9.3.38.21.38
MAC address	60:C5:A8:60:33:E1
Wireless AP mode	Enable
SSID	Solar-WiFi
IP address	10.10.100.253
Wireless STA mode	Disable
Router SSID	WiFi_Burn-in
Encryption method	WAP/WAP2-PSK
Encryption algorithm	AES
Router Password	WiFi_Burn-in

Cannot join the network, may be caused by:
No router / weak WiFi signal / password is not correct

★ **Help:** Wizard will help you to complete setting with one minute.

Start Setup

Please select your current wireless network

	SSID	AUTH/ENCRY	RSSI	Channel
<input type="radio"/>	WiFi_Burn-in	WPAPSK/WPA2PSK/TKIP/AES	66	1
<input type="radio"/>	WiFi_Burn-in	WPAPSK/WPA2PSK/TKIP/AES	100	1
<input type="radio"/>	WiFi_Burn-in	WPAPSK/WPA2PSK/TKIP/AES	70	1
<input type="radio"/>	WiFi_Burn-in2	WPAPSK/WPA2PSK/TKIP/AES	72	1

Refresh

★ **Help:** When RSSI of the selected Wi-Fi network is lower than 15%, the connection may be unstable. Please select other available network or shorten the distance between the device and router. If you wireless router does not broadcast SSID, please click "Next" and add a wireless network manually.

Back

Next

3

1. Fill in the password of the router, then click "Next".
2. Click "Complete".

Add wireless network manually

Network name (SSID)	WiFi-Test
Encryption method	WPA/WPA2-PSK
Encryption algorithm	AES

Please enter the wireless network password:

Password (8-63 bytes)	Router password
show psk	

Note: Case sensitive for SSID and password, Please make sure all parameters of wireless network are matched with router, including password.

Back

Next

Save success!

Click "Complete", the current configuration will take effect after restart.

If you still need to configure the other pages of information, please go to complete your required configuration.

Configuration is completed, you can log on the Management page to restart device by Click on "OK" button.

Confirm to complete?

Back

Complete

Note:

If the Wi-Fi module fails to connect after correct passwords are entered, check that there are not special characters used that are not supported by module. (Supported standard characters: 0-9, a-z, A-Z, supported special characters: -!@#%&*()_+~[]{}|';<>? ,/ , characters not mentioned above are not supported by default.)

Note:

1. Please make sure the password, Encryption method / algorithm is the same as the router's.
2. Under normal operation, the Wi-Fi LED on inverter will change from double blink to quadruple blink then to solid status, which means Wi-Fi has connected to the server successfully.
3. Wi-Fi configuration could also be done on LGES PV Master APP, details please check on LGES PV Master.

Wi-Fi Reset & Restore

Reset means rebooting the Wi-Fi module, the Wi-Fi settings will automatically be reprocessed and saved.
Restore means resetting the WiFi module to the default factory setting then requires configuration.

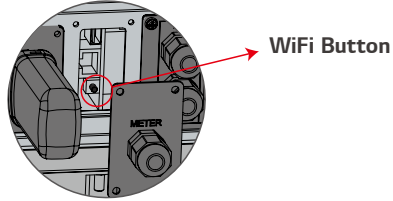
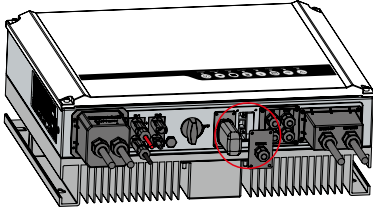

Wi-Fi Reset

Short press the reset button.
The WiFi LED will blink for a few seconds.

Wi-Fi Restore

Long press the reset button more than 3s.
The Wi-Fi indicator will double blink until the Wi-Fi is configured again.

Note:

Wi-Fi Reset & Restore function is only used when:

1. Wi-Fi loses connection to internet or cannot connect to LGES PV Master successfully.
2. Cannot find "Solar-WiFi signal" or have other Wi-Fi configuration problems.
3. Please do not use this button if Wi-Fi monitoring works well.
4. If you need to replace the module, please use the unlock tool, page 29.

3.2 Startup/Shutdown Procedure

Start-up Procedure:

1. Turn on all "PV ARRAY D.C. ISOLATOR(S)" located adjacent to or below the inverter.
2. If a battery is connected to the inverter, turn on "BATTERY DC ISOLATOR".
3. Turn on either the "MAIN SWITCH (INVERTER SUPPLY)" located in the switchboard or the "INVERTER AC ISOLATOR" adjacent to or below the inverter.

Shutdown Procedure:

1. Turn off either the "MAIN SWITCH (INVERTER SUPPLY)" located in the switchboard or the "INVERTER AC ISOLATOR" adjacent to or below the inverter.
2. Turn off all "PV ARRAY D.C. ISOLATOR(S)" located adjacent to or below the inverter.
3. If a battery is connected to the inverter, turn off "BATTERY DC ISOLATOR".

3.3 LGES PV Master App

LGES PV Master is an external monitoring /configuration application for LGES hybrid inverters, used on smart phones or tablet for both Android and iOS system. Features include:

1. Edit system configuration according to customer needs
 2. Check firmware version
 3. Set safety region by country and region A, B or C according to local utility requirement
 4. Adjust export limit
 5. Monitor and check the performance of the hybrid system
- Please download "LGES PV Master App User Manual" at <https://www.lgessbattery.com/m/au/home-battery/product-info.lg?sn=362>

Note:

For Australian safety region, set to A, B or C, according to local utility requirement. After the setting is completed, some parameters will take effect according to region, such as PU curve, QU curve, trip protection etc. To change settings, please refer to the App User Manual, QR code below.



LGES PV Master App

3.4 LG RESU Home Monitor App

LG RESU Home Monitor is an online monitoring system. After completing the installation of communication connection, you can also access www.lgresuhomemonitor.com. Please contact technical support for more operation of LG RESU Home Monitor or download the App User Manual via QR code below.



LG RESU HOME App



App User Manual Link

04 OTHER

4.1 Error Messages.

The error messages below will be displayed on LGES PV Master App or reported by e-mail if an error occurs.

ERROR MESSAGE	EXPLANATION	REASON	SOLUTIONS
Utility Loss	Public grid power is not available (power lost or on-grid connection fails)	Inverter does not detect the connection of grid	<ol style="list-style-type: none">1. Check (use multi-meter) if AC side has voltage . Make sure grid power is available.2. Make sure AC cables are connected tightly and well.3. If all is well, please try to turn off AC breaker and turn on again in 5 mins.
VAC Failure	Grid voltage is not within permissible range	Inverter detects that AC voltage is beyond the normal range required by the safety country	<ol style="list-style-type: none">1. Make sure safety country of the inverter is set right.2. Check (use multi-meter) if the AC voltage (Between L & N) is within a normal range (also on AC breaker side)<ol style="list-style-type: none">a. If the AC voltage is high, then make sure the AC cable complies with that required on user manual and the AC cable is not too long.b. If the voltage is low, make sure the AC cable is connected well and the jacket of the AC cable is not compressed into the AC terminal.3. Make sure the grid voltage of your area is stable and within normal range.
FAC Failure	Grid frequency is not within permissible range	Inverter detects that the grid frequency is beyond the normal range required by the safety country	<ol style="list-style-type: none">1. Make sure the safety country of the inverter is set right.2. If safety country is right, then please check on the inverter display if AC frequency (Fac) is within a normal range.3. If FAC failure only appears a few times and is resolved soon, it should be caused by occasional grid frequency instability.
Over Temperature	Temperature inside of the inverter is too high	The inverter's working environment leads to a high temperature condition	<ol style="list-style-type: none">1. Try to decrease surrounding temperature.2. Make sure the installation complies with the instruction on inverter user manual.3. Turn off the inverter.

Isolation Failure	Ground insulation impedance of PV string is too low	Isolation failure could be caused by multiple reasons like that the PV panels are not grounded well, DC cable is broken, PV panels are aged or surrounding humidity is comparatively heavy, etc.	<ol style="list-style-type: none"> 1. Use multi-meter to check if the resistance between earth & inverter frame is close to zero. If it's not, please ensure that the connection is well. 2. If the humidity is too high, isolation failure may occur. 3. Check the resistance between PV1+/PV2+/PV3+/PV4+/BAT+/PV- to earth. If the resistance is lower than the minimum isolation resistance shown in the table(chapter 2.4.2) , check the system wiring connection. 4. Try to restart the inverter. Check if the fault still occurs. If not, it means it is caused by an occasional situation, or contact technical support.
Ground Failure	Ground leakage current is too high	Ground failure could be caused by multiple reasons like that the neutral cable on the AC side is not connected well or the surrounding humidity is comparatively heavy, etc.	Check (use multi-meter) if there is voltage (normally should be close to 0V) between earth & inverter frame. If there is a voltage, it means the neutral & ground cables are not connected well on the AC side. If it happens only in the early morning/dawn /rainy days with higher air humidity and is recovered soon, it should be normal.
Relay Check Failure	Self checking of relay failure	Neutral & ground cables are not connected well on AC side or just an occasional failure	Check (use multi-meter) if there is high voltage (normally should be lower than 10V) between N & PE cable on the AC side. If the voltage is higher than 10V, it means the Neutral & ground cable are not connected well on AC side or restart inverter.
DC Injection High	/	The inverter detects a higher DC component in AC output	Try to restart the inverter, check if it still occurs. If not, it is just an occasional situation. Otherwise, contact technical support immediately.
EEPROM R/W Failure	/	Caused by a strong external magnetic field etc.	Try to restart the inverter, check if it still occurs. If not, it is just an occasional situation. Otherwise, contact technical support immediately.
SPI Failure	Internal communication failure	Caused by a strong external magnetic field etc.	Try to restart the inverter, check if it still occurs. If not, it is just an occasional situation. Otherwise, contact technical support immediately.
DC Bus High	BUS voltage is over-high	/	Try to restart the inverter. Check if the fault still occurs. If not, it means it is caused by an occasional situation, or contact technical support.

Back-Up Over Load	Back-up side is over loaded	Total back-up load power is higher than the back-up nominal output power	Decrease back-up loads to make sure the total load power is lower than back-up nominal output power.
-------------------	-----------------------------	--	--

4.2 Troubleshooting

For PC: <https://www.lgessbattery.com/au/home-battery/product-info.lg?sn=362>

For Mobile: <https://www.lgessbattery.com/m/au/home-battery/product-info.lg?sn=362>



User Manual Download Link

Questions & Answers (Q & A)

About the Wi-Fi Configuration

Q: Why can't I find the Solar-Wi-Fi* signal on mobile devices?

A: Normally Solar-WiFi* signal can be found right after inverter has powered up. But Solar-Wi-Fi signal will disappear when LGES inverter connects to internet. If changes to the setting are required, connect to the router for change. If you can't find the WiFi signal or connect to the router, then please try to reload Wi-Fi (please refer to User manual page 21).

Q: Why can't I connect to the Solar-Wi-Fi* signal on my phone?

A: The Wi-Fi module can only connect to one device at a time. If the signal is already connected to another device at the same time, you will not be able to connect to the signal.

Q: Why does the Wi-Fi module fail to connect to network after I choose the right router hotspot and enter the right passwords?

A: It's possible that there are special characters not supported by module in the hotspot passwords. Please modify the password to consist of only Arabic numerals or uppercase /lowercase letters.

About Battery Operation

Q: Why does the battery not discharge when the grid is not available but it discharges normally when the grid is available?

A: In the APP, the off-grid output and backup function should be turned on to force the battery to discharge under off-grid mode.

Q: Why is there no output on the backup side?

A: For backup supply, "Backup Supply" on the LGES PV Master App must be turned on. In off-grid mode or when the grid power is disconnected, the "Off-Grid Output Switch" function must be turned on as well.

Note: When turning the "Off-Grid Output Switch" on, do not restart the inverter or battery. Otherwise, the function will be switched off automatically.

Q: The battery cannot be fully charged to 100%?

A: The battery will stop charging when the battery voltage reaches the charge voltage set on LGES PV Master App.

Q: Why does the battery switch always trip when it starts up (RESU battery)?

A: The switch of RESU battery normally trips because of following reasons:

1. Battery DIP switches not set correctly
2. BMS communication fails. (10 minute delay to trip).
3. Battery Voltage is too low (<35V), battery trips to protect itself
4. An electrical short-cut happened on battery connection side. Or for other reasons please contact technical support.

Q: Which battery should I use for the inverter?

A: LG Energy Solution RESU6.5, RESU10, RESU12, RESU13 (end of line)

About LGES PV Master Operation And Monitoring

Q: Why can't I save settings on the LGES PV Master App?

A: This could be caused by losing the connection to Solar-Wi-Fi*.

1. Make sure you have already connected to Solar-Wi-Fi* (make sure that no other devices are connected) or to the router (if Solar-Wi-Fi* is connected to the router). The APP homepage shows the connections.
2. Make sure you restart the inverter 10 mins after you have changed any settings because the inverter will save the settings every 10 mins while operating in normal mode. We recommend that parameter settings be changed when the inverter is in wait mode.

Q: Why are the data displayed on the homepage different from the param page, like charge/discharge, PV value, load value, or grid value?

A: The data refresh frequency is different, so there will be data discrepancies between different pages on the APP as well as between these shown on the portal and APP.

Q: Some columns show NA, like battery SOH, etc. Why does that happen?

A: NA means that the App has not received data from the inverter or server because of communication problems, such as battery communications and the communications between inverter and the App.

About the Smart Meter And Power Limit Function

Q: How to activate the output power limit function?

A: This function can be activated by following these steps:

1. Make sure the Smart Meter connections and communications are functioning correctly.
2. Turn on the export power limit function and set the maximum output power to the grid on the APP.

Note: Even if the output power limit is set to 0W, there might still be a deviation of a maximum of 100 W when exporting to the grid.

Q: Why is there still power exporting to the grid after I have set the power limit to 0 W?

A: Export limit can be 0W theoretically, but there can be a measurement deviation of around 50-100W.

Q: Can I use other meter brands to take over from the Smart Meter in the system or to change settings in Smart Meter?

A: Generally, no, because the communication protocol is integrated into inverter and Smart Meter, other brand meters cannot communicate. Also any manual setting change could cause Meter communication failure. An exception is when using an LG Energy Solution approved meter for VPP operations.

Q: What is the maximum current allowed to pass through the CT on the Smart Meter?

A: The maximum current for the CT is 120A.

Other Questions

Q: Is there a quick way to make the system work?

A: For the shortest resolution, please refer to "LGES Quick Installation Instructions" and to the "LGES PV Master App Instructions".

Q: What kind of load can I use to connect to the backup side?

A: Please refer to User Manual on page 14.

Q: Will the warranty of the inverter still be valid if, for some special conditions, we cannot follow 100% of the User Manual instructions for installation or operation?

A: Normally we still provide technical support for problems caused by not following the instructions in the User Manual. However we cannot guarantee any replacements or returns. So, if there are any special conditions for which you cannot follow the instructions 100%, please contact the Technical Support department for suggestions.

4.3 Disclaimer

The inverters are transported, used and operated under environmental and electrical conditions. The manufacturer has the right to not provide technical support services or assistance under the following conditions:

- Inverter is damaged during transfer.
- Inverter is out of warranty year and extended warranty is not bought.
- Inverter is installed, refitted or operated in improper ways without authority from manufacturer.
- Inverter is installed or used under improper environment or technical condition mentioned in this user manual, without authority from manufacturer.
- Installation or configuration of the inverter does not follow requirements mentioned in this user manual.
- The inverter is installed or operated against the requirements or warnings that are mentioned in this user manual.
- Inverter is broken or damaged by any force majeure like lightning, earthquake, fire hazard, storm and volcanic eruption etc.
- Inverter is disassembled, changed or updated on software or hardware without authority from manufacturer.
- Inverter is installed, used or operated against any related items in international or local policies or regulations.
- Any non-compatible batteries, loads or other devices connected to inverter.

Note: The manufacturer retains the right to explain all of the contents in this User Manual. To ensure IP65, the inverter must be sealed well; please install the inverters within one day of unpacking; otherwise, please seal all unused terminals /holes; unused terminals/holes are not allowed to remain open; and confirm that there is no risk of water or dust entering any terminals/holes.

Maintenance

Maintaining Item	Maintaining Method	Maintaining Period
System Clean	Check the heat sink, air intake, and air outlet for foreign matter or dust.	Once 6-12 months
DC Switch	Turn the DC switch on and off ten consecutive times to make sure that it is working properly.	Once a year
Electrical Connection	Check whether the cables are securely connected. Check whether the cables are broken, or whether there is any exposed copper core.	Once 6-12 months
Sealing	Check whether all the terminals and ports are properly sealed. Reseal the cable hole if it is not sealed or too big.	Once a year
THDi Test	For Australia requirements, in the THDi test, there should add Zref between inverter and mains. L: $0.24 \Omega + j0.15 \Omega$; N: $0.16 \Omega + j0.10 \Omega$ L: $0.15 \Omega + j0.15 \Omega$; N: $0.1 \Omega + j0.1 \Omega$	As needed

- Wi-Fi module:

Replace or remove the Wi-Fi module using the Wi-Fi unlock tool module remover, which is delivered in the package. Remove the communication terminal next to the Wi-Fi module first. Place the remover horizontally on the Wi-Fi module, then turn the remover to 90° to fasten it and the module together. Press the remover and pull the module to remove it as the following figure shows.

Notice: If you need to repair or replace parts, contact the Technical Support Service team

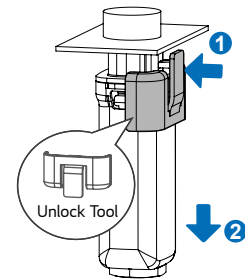

4.4 Technical Parameters

Technical Data	LGES-5048*8
Battery Input Data	
Battery Type*1	Li-Ion
Nominal Battery Voltage (V)	48
Battery voltage range (V)	40-60
Max. Charging Voltage (V)	≤60 (Configurable)
Max. Charging Current (A)*1	100
Max. Discharging Current (A)*1	100
Max charge power (W)	4600
Max discharge power (W)	4600
Nominal Battery Capacity (Ah)	126-252
Charging Mode for Li-Ion Battery	Self-adaption to BMS
PV String Input Data	
Max. DC Input Power without battery (W)	6500
Max. DC Input Power with battery (W)	7500
Max. DC Input Voltage (V)	580
MPPT Range (V)	125-550
Start-up Voltage (V)	125
Min. Feed-in Voltage(V)*2	150
MPPT Range for Full Load (V)	215-500
Nominal DC Input Voltage (V)	360
Max. Input Current (A)	11/11
Max. Short Current (A)	13.8/13.8
Max. Backfeed Current to The Array (A)	0
No. of MPP Trackers	2
No. of Strings per MPP Tracker	1
AC Output Data (On-grid)	
Nominal Apparent Power Output to Utility Grid (VA)*7	5000
Max. Apparent Power Output to Utility Grid (VA)*3	5000
Nominal Apparent Power from Utility Grid (VA)	9200

Max. Apparent Power from Utility Grid (VA)	9200
Nominal Output Voltage (V)	230
Output Voltage Range (V)	0-300
Nominal Output Frequency (Hz)	50/60
AC Grid Frequency Range (Hz)	45-65
Max. AC Current Output to Utility Grid (A)	24.5
Max. AC Current From Utility Grid (A)	40
Max. Output Fault Current(peak and duration) (A)	43A,0.2s
Inrush Current(peak and duration) (A)	60A,3us
Maximum output overcurrent protection (A)	30
Output Power Factor	~1 (Adjustable from 0.8 leading to 0.8 lagging)
Output THDi (@Nominal Output)	<3%
AC Output Data (Back-up)	
Back-up Nominal apparent power (VA)	4600
Max. Output Apparent Power (VA)	4600
Peak Output Apparent Power (VA) ⁴	6900, 10sec
Nominal Output Current (A)	20
Max. Output Current (A)	20
Max. Output Fault Current(peak and duration) (A)	43A,0.2s
Inrush Current(peak and duration) (A)	60A,3us
Maximum output overcurrent protection (A)	30
Nominal Output Voltage (V)	230 (±2%)
Nominal Output Frequency (Hz)	50/60 (±0.2%)
Output THDv (@Linear Load)	<3%
Efficiency	
Max. Efficiency	97.6%
Max. Battery to Load Efficiency	94.0%
Europe Efficiency	97.0%
MPPT Efficiency	99.9%

Protection	
Anti-islanding Protection	Integrated
PV String Input Reverse Polarity Protection	Integrated
Insulation Resistor Detection	Integrated
Residual Current Monitoring Unit	Integrated
Output Over Current Protection	Integrated
Output Short Protection	Integrated
Output Over Voltage Protection	Integrated
General Data	
Operating Temperature Range (°C)	-25-60
Relative Humidity	0-95%
Operating Altitude (m)	3000
Cooling	Natural Convection
Noise (dB)	< 25
User Interface	LED & APP
Communication with BMS ⁵	RS485; CAN
Communication with Meter	RS485
Communication with Portal	Wi-Fi
Weight (kg)	30
Size (Width*Height*Depth mm)	516*440*184
Mounting	Wall Bracket
Protection Degree	IP65
Standby Self Consumption (W)	< 13
Topology	Non-isolated
DC Connector	MC4 (4-6mm ²)
AC Connector	Feed-Through Terminal Blocks UW10
Protective class	Class I
Environmental Category	4K4H
Storage environments(°C)	-40-85°C
Overvoltage Category	DCII; ACIII

The Decisive Voltage Class (DVC)	Battery: A PV: C AC: C COM: A
Active anti-islanding method	AFDPF+AQDPF
Type of electrical supply system	Single phase TN/TT system
Certifications & Standards*⁶	
Grid Regulation	VDE-AR-N 4105; VDE 0126-1-1 EN 50549-1;G98,G100; CEI 0-21;AS/NZS4777.2 NRS 097-2-1;
Safety Regulation	IEC62109-1&2, IEC62040-1
EMC	EN61000-6-1, EN61000-6-2, EN61000-6-3, EN61000-6-4 EN 61000-4-16, EN 61000-4-18, EN 61000-4-29
<p>*1: The actual charge and discharge current also depends on the battery.</p> <p>*2: When there is no battery connected, inverter starts feeding in only if string voltage is higher than 200V.</p> <p>*3: 4600 for VDE 0126-1-1 &VDE-AR-N4105 &NRS 097-2-1, 5100 for CEI 0-21</p> <p>*4: Can be reached only if PV and battery power is enough.</p> <p>*5: CAN communication is configured by default.</p> <p>*6: Not all certifications & standards listed, check the official website for details.</p> <p>*7: 4600 for VDE 0126-1-1 &VDE-AR-N4105 &NRS 097-2-1, 4600 for CEI 0-21</p> <p>*8: FOR AUSTRALIA ONLY. Model LGES-5048-NS inverters are designed without built in DC switch. For inverters designed with built in DC switch, the model name should be LGES-5048.</p>	

LG Energy Solution Australia Pty Ltd
Unit 12, 35 Dunlop Rd, Mulgrave, VIC 3170

Support Tel. : 1300 178 064 [AEST Business hours]
Support email : essserviceau@lgensol.com
www.lghomebattery.com.au



Keep this manual for later use.

© 2021 LG Energy Solution ESS Battery Division
PARC1, 108, Yeoui-daero, Yeongdeungpo-gu, Seoul, Republic of Korea, 07335
www.lgessbattery.com/au <https://www.lgensol.com>



340-00783-00

V1.1-2022-04-06